

# BAS-341F

# BAS-342F

Programmable Electronic Pattern Sewer  
with Cylinder Bed



## Specifications

	BAS-341F	BAS-342F
Machine head	Lock stitch pattern tacking sewing machine (with large shuttle hook)	
Application	Medium and heavy	
Sewing speed	2,500 rpm (When stitch length is 3 mm or less)	
Stitch length	0.05-12.7 mm	
Sewing area X-Y(mm)	250 × 150 mm	300 × 200 mm
Max. No. of stitches	20,000	
Feed mechanism	Stepping feed, pulse motor drive	
Height of work clamp	Unit type : 30 mm, Separate type : 30 mm	
Stepping presser foot lift stroke	0, 3.0 – 8.0 mm (Factory setting: 3 mm)	
No. of stitches	20,000 stitches per pattern (max. 100 patterns, 360,000 stitches / 2HD floppy disk)	
Needle	DP × 5, DP × 17, MR	
Test function	Operation test function provided for use with low speed drive	
Safety device	Automatic stop function for activation in the event of misoperation realized with intermediate stop function and safety circuits	
Motor	Three-phase 400 W induction motor	
Data storage method	3.5 floppy disk 2HD / 1.44 MB, 2DD	
Pattern editing functions	Line, curve, circle, arc, zigzag stitch, double stitch, parallel stitch, offset, resizing, rotating, etc.	
Power supply	Single-phase 110 V, 220 V, 240V	3-phase 220 V, 380 V, 400 V, 900 VA
Air pressure	0.5 Mpa 1.8l / min	
Machine dimension	1,200 (W) × 1,220 (D) × 860 (Sitting) - 1,130 (Standing)	1,200 (W) × 1,220 (D) × 860 (Sitting) - 1,130 (Standing)
Weight	Machine head: Approx. 80 kg Control box: 10–20 kg (Depending on voltage)	

# BAS-341F-0

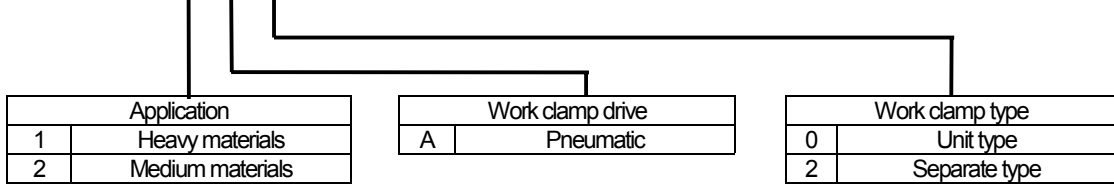

# BAS-342F-0

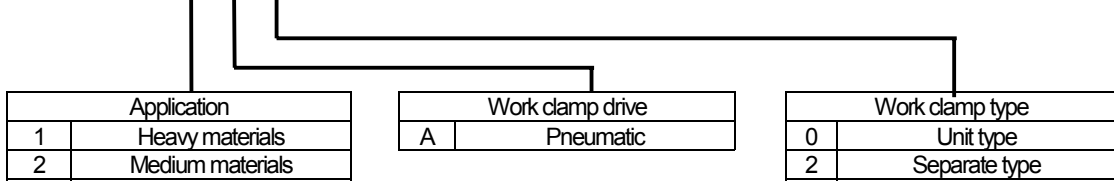

# GAUGE PARTS LIST

Presser foot

[Models BAS-341F, 342F]

A	S42843-001 ★	B	S42844-001	C	S42845-001	D	S42846-001
E	S42847-001	F	157237-001	G	158592-001	J	S42848-001
XA	S42849-101	A-CUT	S40214-001	GL	S20864-001	I	S04887-001
A	152283-101	B	152636-101	C	152637-001	D	154069-001
E	154089-001	J	S13815-001	BL	S49448-001		

The part indicated with ★ is a standard part for BAS-341F & 342F.

**Needle hole plate**

Models BAS-341F, 342F

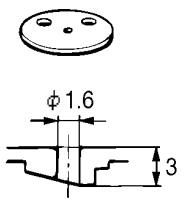
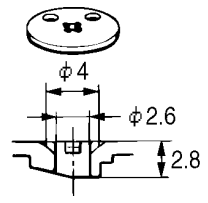
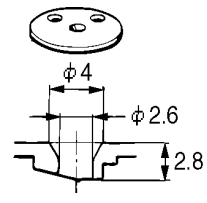
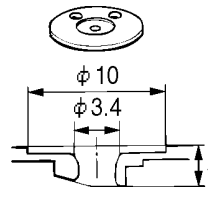
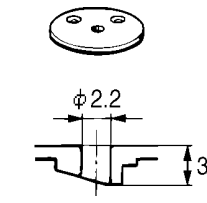
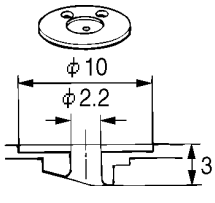
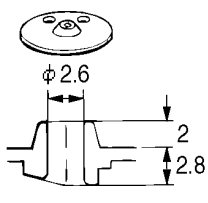
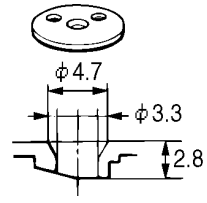
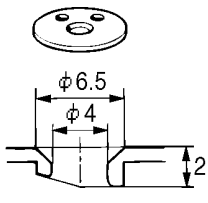
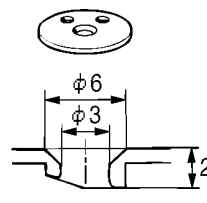
A	S10211-001	D	S29997-001	E	S10212-101 ★	ED	S30925-001	F	S10213-001
									
FD	S30926-001	H	S30450-001	L	S25127-001	M	S34348-001	3	S40217-001
									

The part indicated with ★ is a standard part for BAS-341F & 342F.

**For inner clamping device : Sewing area “ 100 x 60 mm ”**

[Models BAS-341F, 342F]

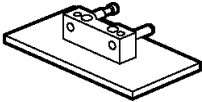
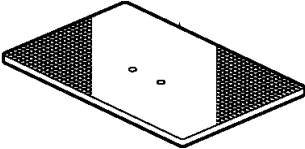
	Part name	Part code	Q'ty
	<Thick 3.2 mm> Inner clamp plate assy, A	S21506-001	1
	<Thick 3.2 mm> Inner clamp plate, A	S21168-001	1

**For inner clamping device : Sewing area “ 250 x 150 mm ”**

[Models BAS-341F, 342F]

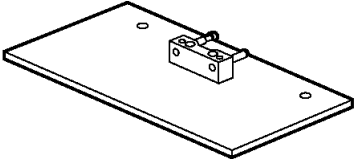
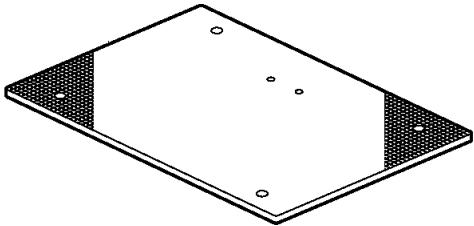
	Part name	Part code	Q'ty
	<Thick 3.2 mm> Inner clamp plate assy, B	S21507-001	1
	<Thick 4.0 mm> Inner clamp plate assy, C	S21508-001	1
	<Thick 3.2 mm> Inner clamp plate, B	S21169-001	1
	<Thick 4.0 mm> Inner clamp plate, C	S21170-001	1

**One-touch cassette clamp assy**

[Models BAS-341F, 342F]

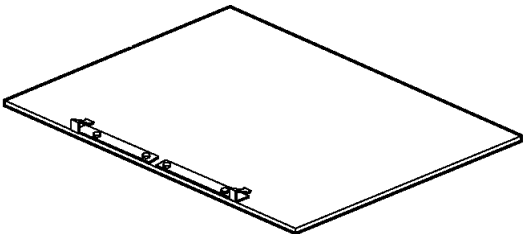
	Part name	Part code	Q'ty
	<Thick 1.0 mm> OT - cassette plate assy	S21476-001	1
	<Thick 2.0 mm> OT - cassette plate assy	S21476-002	1

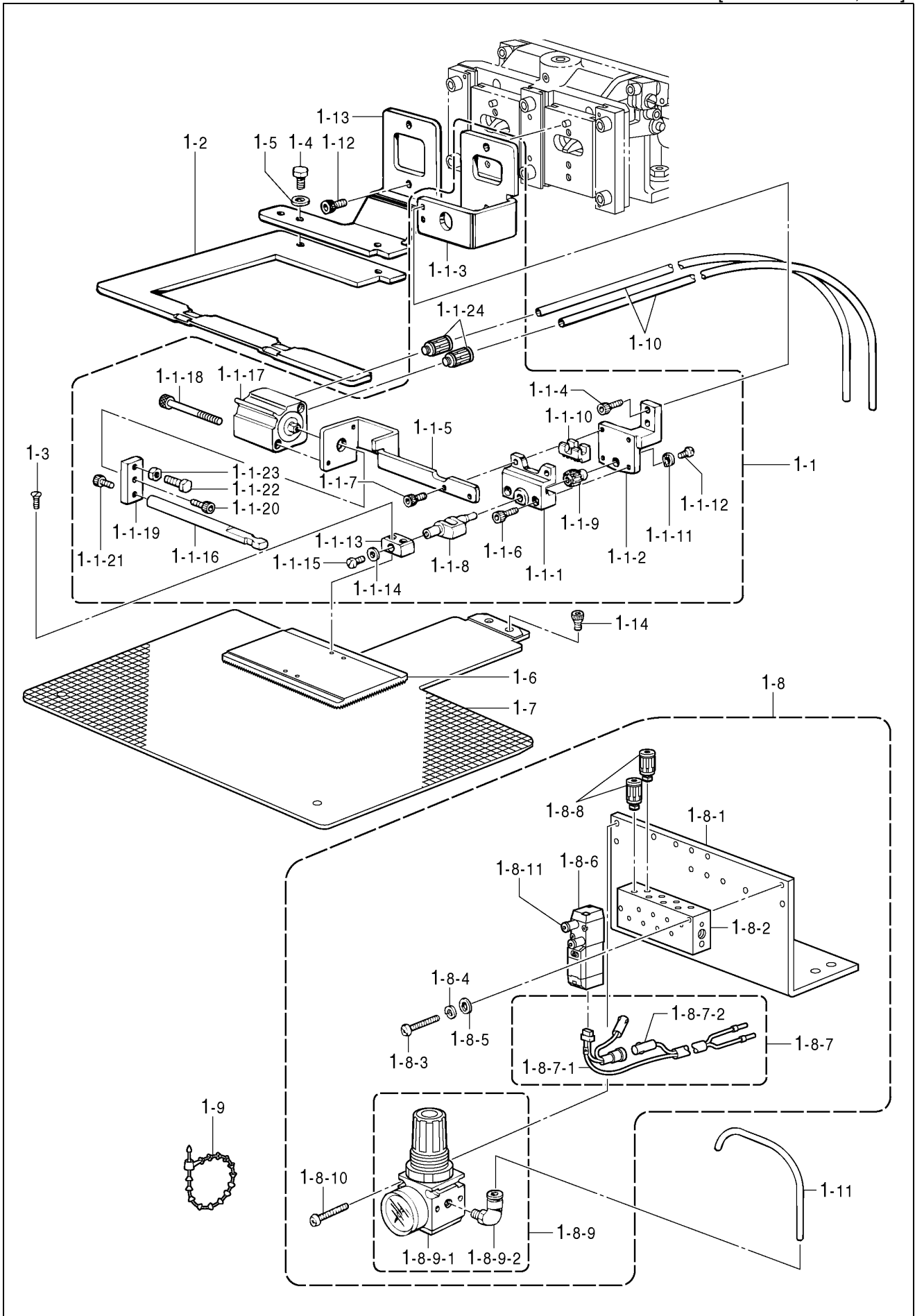

Inner clamping device : Sewing area “ 100 x 60 mm

[Models BAS-341F,342F]

Ref. No.	Part name	Part code	Qty
1	Inner clamping device set	S48507-109	1
1-1	Work clamp crank assy, LA	S19997-109	1
1-1-1	Work clamp crank holder, A	S12634-009	1
1-1-2	Work clamp crank holder, B	S12635-009	1
1-1-3	Work clamp, H	S19998-001	1
1-1-4	Bolt, socket SM4.37 – 40 x 12	018681-232	2
1-1-5	Reverse cylinder bracket	S12638-009	1
1-1-6	Bolt, socket M3 x 12	018301-236	2
1-1-7	Bolt, socket M3 x 10	018301-036	2
1-1-8	Work clamp clank, LA	S05665-001	1
1-1-9	Reverse gear	154235-001	1
1-1-10	Reverse rack	154236-001	1
1-1-11	Washer	145087-001	1
1-1-12	Set screw, SM3.18	149831-101	1
1-1-13	Work clamp plate holder, L	154237-001	1
1-1-14	Washer, plain S3.5	025350-132	1
1-1-15	Screw, SM3.57-40x5	100242-003	1
1-1-16	Reverse rod	S12637-009	1
1-1-17	Reverse cylinder	S12639-001	1
1-1-18	Bolt, socket M3 x 35	S12642-009	2
1-1-19	Joint	S12640-009	1
1-1-20	Bolt, socket M3 x 8	018300-836	1
1-1-21	Bolt, socket M3 x 8	018300-836	1
1-1-22	Bolt, M5 x 12	017501-216	1
1-1-23	Nut, 2 M5	021500-216	1
1-1-24	Half union, Q4M5	S18415-101	2
1-2	Work clamp, external – H1	S20000-001	1
1-3	Screw, flat SM3.18	117291-002	2
1-4	Bolt, SM4.37 x 7	153403-002	2
1-5	Washer, plain M4.37	025680-232	2
1-6	Work clamp plate blank, A	154256-101	1
1-7	Feed plate blank, H - A	S48509-001	1
1-8	Valve assy, 4 reverse ;in-clamp	S49436-009	1
1-8-1	Valve setting plate, 4 – 5H	S31570-209	1
1-8-2	Air manifold, 4	S18735-101	1
1-8-3	Screw, pan M3 x 25	062302-505	2
1-8-4	Washer, spring 2 – 3	028030-242	2
1-8-5	Washer, plain M3	025030-232	2
1-8-6	Solenoid valve	S49432-001	1
1-8-7	Valve harness assy, x 1	S43696-100	1
1-8-7-1	Valve harness	S44746-100	1
1-8-7-2	Valve harness, 24 V	S44750-100	1
1-8-8	Half union, Q4M5	S18415-101	2
1-8-9	Regulator assy	S45252-000	1
1-8-9-1	Regulator	S45253-000	1
1-8-9-2	Joint, 3109-4-10	S45254-000	2
1-8-10	Screw, pan M4 x 40	062404-005	2
1-8-11	Exhaust throttle valve	S03792-001	2
1-9	Bead band	340400-001	2
1-10	Air tube, 4x2.5L = 1900	S15031-008	2
1-11	Urethane tube, S	S20006-000	1
1-12	Bolt, socket M5 x 12	018501-222	2
1-13	Work clamp, SEL - H	S19999-001	1
1-14	Screw, round w / socket SM4.37	S10352-101	2

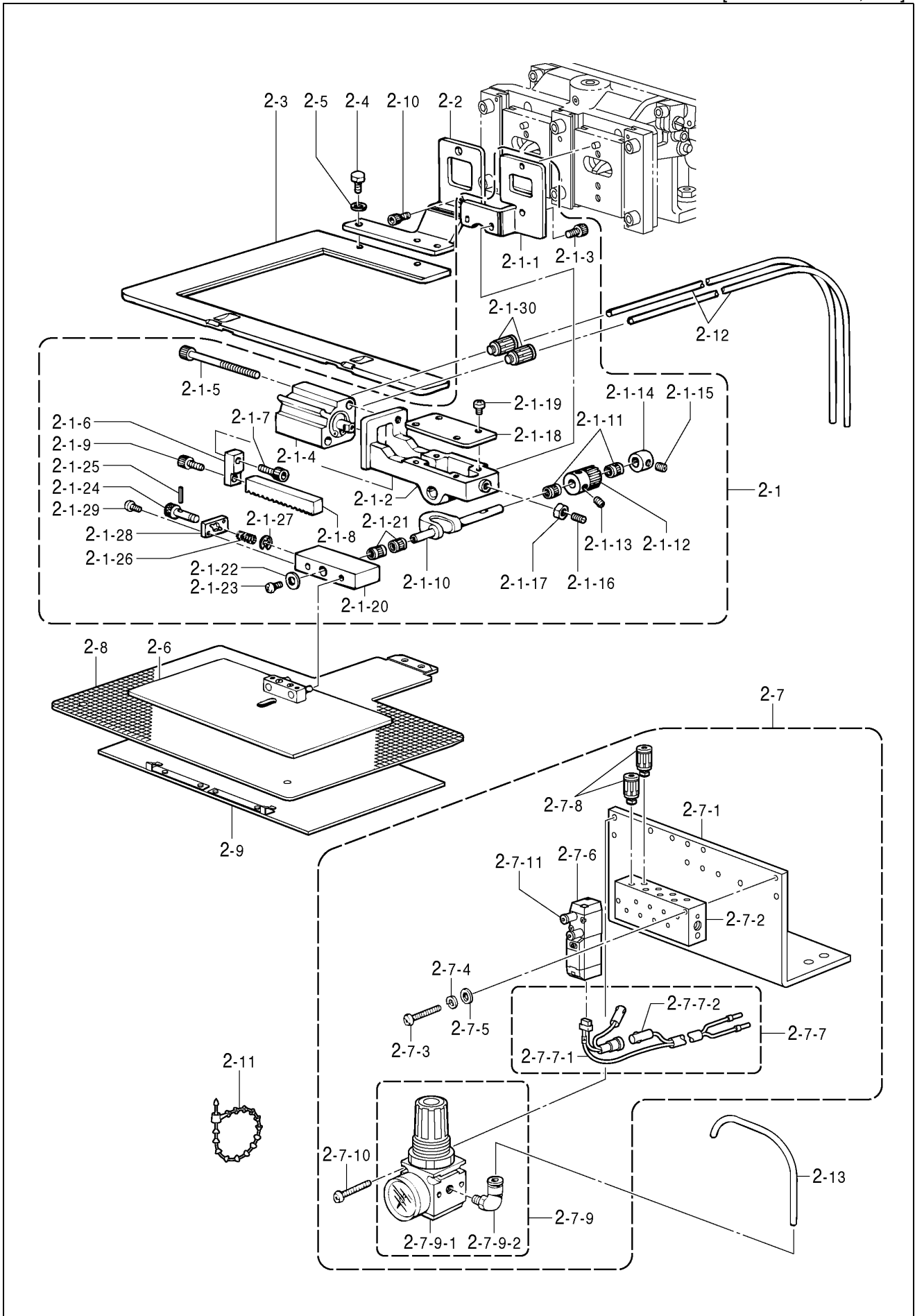



Inner clamping device : Sewing area “ 250 x 150 mm

[Models BAS-341F,342F]

Ref. No.	Part name	Part code	Qty
2	Inner clamping device set, L	S48511-109	1
2-1	Work clamp clank assy	S21505-109	1
2-1-1	Work clamp foot, M	S21151-001	1
2-1-2	Holder, work crank	S21152-001	1
2-1-3	Bolt, socket M5 x 10	018501-036	2
2-1-4	Reverse cylinder	S21156-000	1
2-1-5	Bolt, CQ2 M5 x 45	S24729-000	2
2-1-6	Reverse back joint	S21157-001	1
2-1-7	Bolt, socket M5 x 14	018501-436	2
2-1-8	Reverse rack	S21158-000	1
2-1-9	Bolt, socket M5 x 12	018501-236	1
2-1-10	Work clamp clank	S21159-001	1
2-1-11	Needle bearing, 6	S21153-000	2
2-1-12	Reverse gear	S21160-000	1
2-1-13	Set screw, socket (CP) SM4.76	014710-522	2
2-1-14	Set screw collar, H - shaft	155067-001	1
2-1-15	Set screw, socket (CP) M4 x 4	014400-432	1
2-1-16	Set Screw, SM6.35	115012-002	1
2-1-17	Nut, SM6.35	150554-002	1
2-1-18	Clamp plate, reverse back	S21154-001	1
2-1-19	Screw, pan M5 x 10	062501-006	4
2-1-20	Holder, clasper	S21162-001	1
2-1-21	Needle bearing, 6	S21153-000	2
2-1-22	Washer, thrust 3.6	S21161-001	1
2-1-23	Screw, pan SM3.57 - 40 x 6	062670-616	1
2-1-24	Positioning pin	S20284-001	1
2-1-25	Pin, spring roll 1.4 x 8	047140-850	1
2-1-26	Spring	S20285-001	1
2-1-27	Retaining ring, E3	048030-342	1
2-1-28	Side plate	S21163-001	1
2-1-29	Screw, pan M3 x 6	062300-616	1
2-1-30	Half union, Q4M5	S18415-101	2
2-2	Work clamp, U - external	S21167-001	1
2-3	Work clamp, external	S21171-001	1
2-4	Bolt, SM4.37 x 7	153403-002	2
2-5	Washer, plain M4.37	025680-232	2
2-6	Inner clamp plate assy, B	S21507-001	1
2-7	Valve assy, 4 reverse; in-clamp	S49436-009	1
2-7-1	Valve setting plate, 4 – 5H	S31570-209	1
2-7-2	Air manifold, 4	S18735-101	1
2-7-3	Screw, pan M3 x 25	062302-505	2
2-7-4	Washer, spring 2 – 3	028030-242	2
2-7-5	Washer, plain M3	025030-232	2
2-7-6	Solenoid valve	S49432-001	1
2-7-7	Valve harness assy, x 1	S43696-100	1
2-7-7-1	Valve harness	S44746-100	1
2-7-7-2	Valve harness, 24 V	S44750-100	1
2-7-8	Half union, Q4M5	S18415-101	2
2-7-9	Regulator assy	S45252-000	1
2-7-9-1	Regulator	S45253-000	1
2-7-9-2	Joint, 3109-4-10	S45254-000	2
2-7-10	Screw, pan M4 x 40	062404-005	2
2-7-11	Exhaust throttle valve	S03792-001	2
2-8	Feed plate blank, AT = 1.0	S47612-001	1
2-9	OT – cassette plate assy	S21476-001	1
2-10	Bolt, socket M5 x 12	018501-222	2
2-11	Bead band	340400-001	2
2-12	Air tube, 4x2.5L = 1900	S15031-008	2
2-13	Urethane tube, S	S20006-000	1

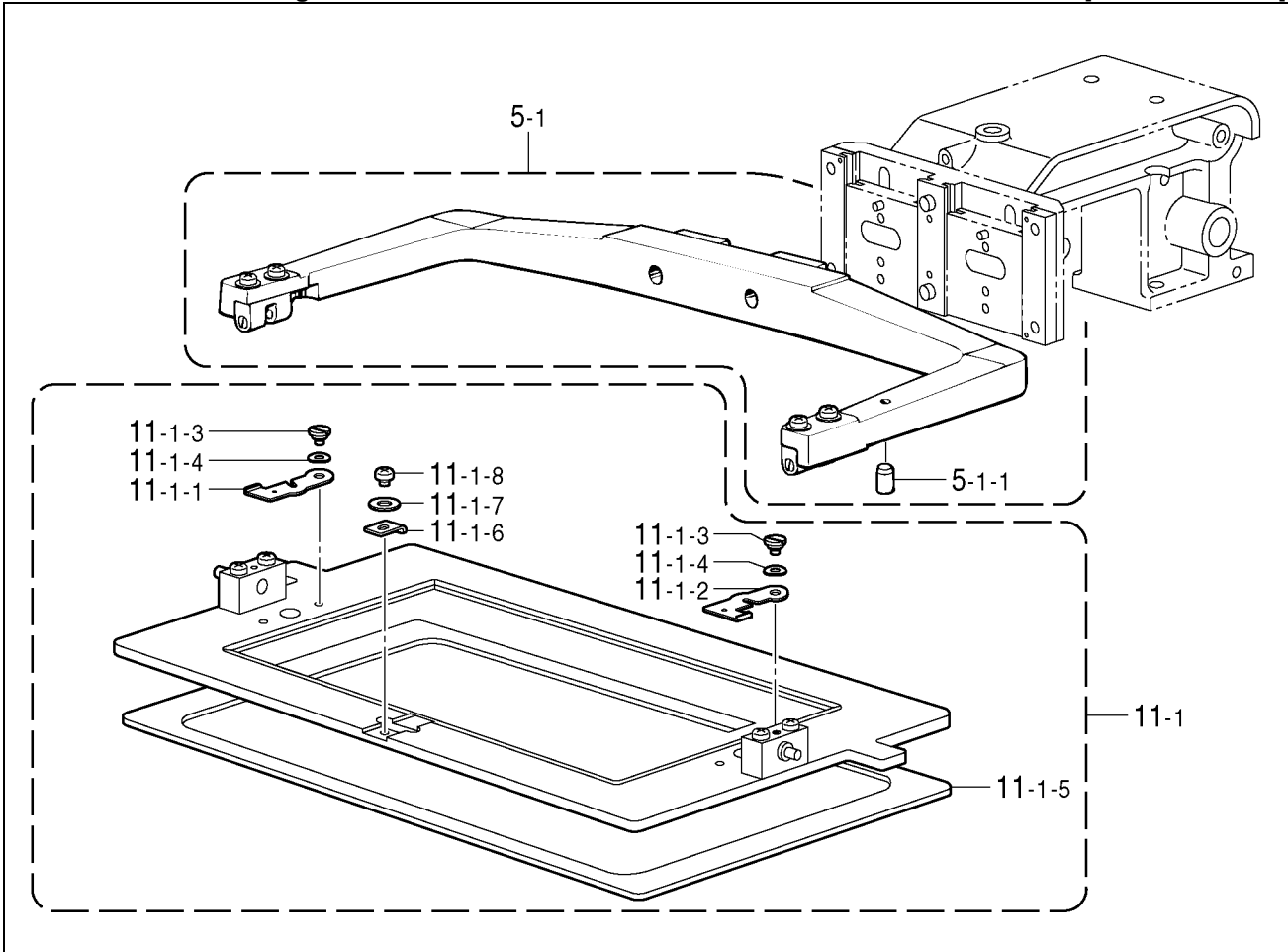

Ref. No.	Part name	Part code	Qty
5-1	Work clamp assy, UNL	S19609-009	1
5-1-1	Rubber cap, 10.7	104832-009	2
11-1	Work clamp plate assy, UNL 341	S47102-101	1
11-1-1	Stopper, L OT – support pin	S47103-001	1
11-1-2	Stopper, R OT – support pin	S47104-001	1
11-1-3	Shoulder screw, SM4.37	159269-001	2
11-1-4	Washer, wave spring 6.45	107017-002	2
11-1-5	Cushion, UNL work clamp plate	S19626-000	1
11-1-6	Adjusting plate	S18026-001	1
11-1-7	Washer, plain M4.37	025680-232	1
11-1-8	Screw, pan SM4.37 – 40 x 5	062680-512	1

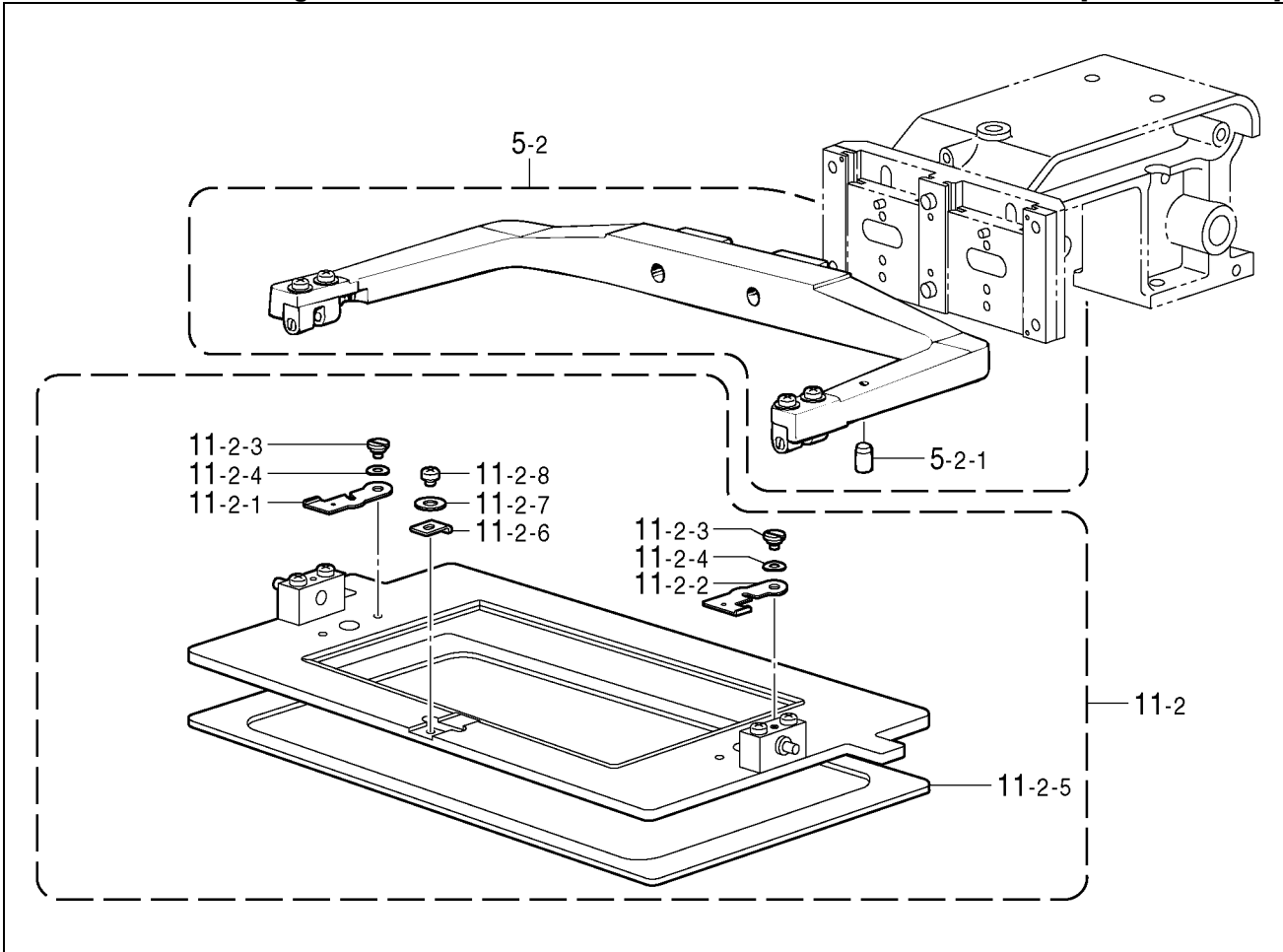

Ref. No.	Part name	Part code	Qty
5-2	Work clamp assy, UNS	S19620-009	1
5-2-1	Rubber cap, 10.7	104832-009	2
11-2	Work clamp plate assy, UNS 341	S47105-001	1
11-2-1	Stopper, L OT – support pin	S47103-001	1
11-2-2	Stopper, R OT – support pin	S47104-001	1
11-2-3	Shoulder screw, SM4.37	159269-001	2
11-2-4	Washer, wave spring 6.45	107017-002	2
11-2-5	Cushion, UNS work clamp plate	S19613-000	1
11-2-6	Adjusting plate	S18026-001	1
11-2-7	Washer, plain M4.37	025680-232	1
11-2-8	Screw, pan SM4.37 – 40 x 5	062680-512	1

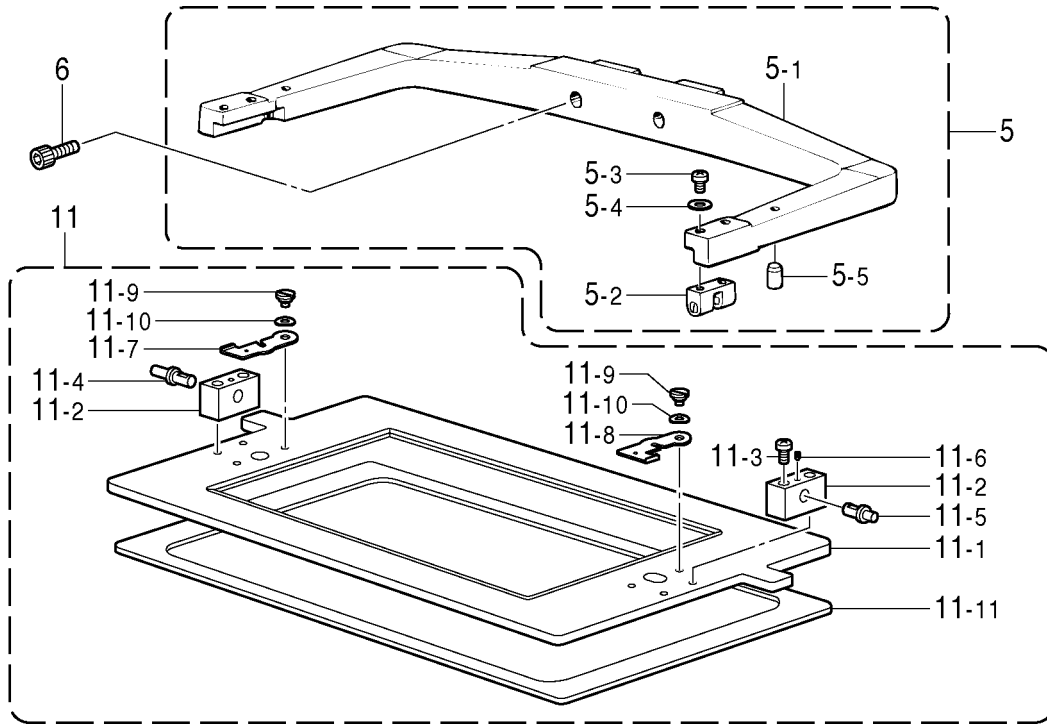

Ref. No.	Part name	Part code	Qty
5	Work clamp assy, UN 300	S31164-009	1
5-1	Work clamp, UN 300	S31165-009	1
5-2	Shaft support	S17829-001	2
5-3	Screw, pan SM4.37-40x14	062681-412	4
5-4	Washer	100645-003	4
5-5	Rubber cap, 10.7	104832-001	2
6	Bolt, socket M5x25	018502-522	2
11	Work clamp plate assy, UNS 342	S47289-101	1
11-1	Work clamp plate, UN 342	S48624-001	1
11-2	Hinge, work clamp plate	S17836-001	2
11-3	Screw, pan SM4.37-40x16	062681-612	4
11-4	Hinge shaft, L W-clamp plate	S17837-001	1
11-5	Hinge shaft, R W-clamp plate	S18014-001	1
11-6	Set screw, socket (CP) SM4.76	014710-522	2
11-7	Stopper, L OT – support pin	S47103-001	1
11-8	Stopper, R OT – support pin	S47104-001	1
11-9	Shoulder screw, SM4.37	159269-001	2
11-10	Washer, wave spring 6.45	107017-002	2
11-11	Cushion, w - clamp plate UN	S31168-000	1

Blank for work clamp

[Models BAS-341F]

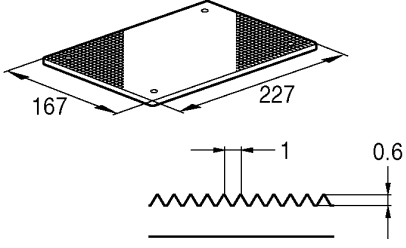
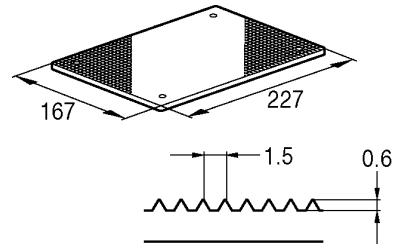
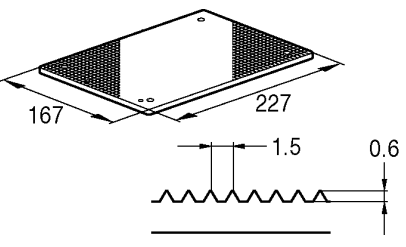
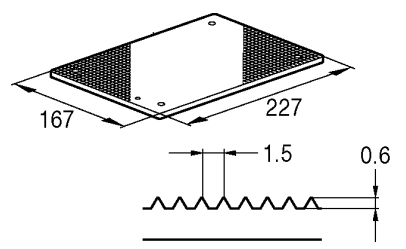
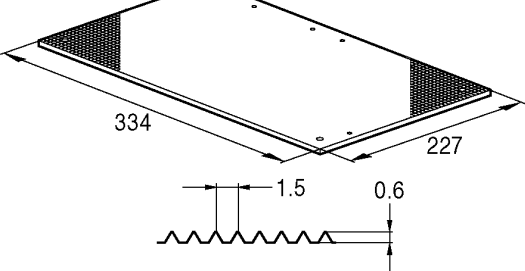
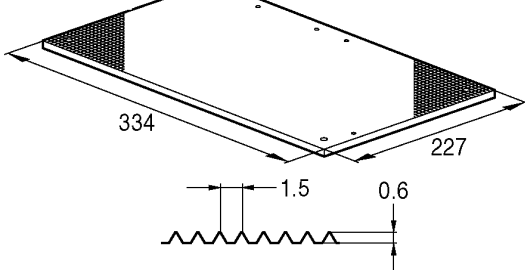
	Part name	Part code	Qty
	<p>&lt;Thick 3.2 mm&gt; Work clamp blank, E-1 T=3.2</p>	<p>S17979-001</p>	<p>1</p>
	<p>&lt;Thick 6.0 mm&gt; Work clamp blank, E-4 T=6.0</p>	<p>S17981-001</p>	<p>1</p>
	<p>&lt;Thick 4.0 mm&gt; Work clamp blank, L T=4.0</p>	<p>S19599-001</p>	<p>1</p>
	<p>&lt;Thick 4.0 mm&gt; Work clamp blank, R T=4.0</p>	<p>S19600-001</p>	<p>1</p>
	<p>&lt;Thick 3.2 mm&gt; Work clamp blank, UN-1 T=3.2</p>	<p>S21723-001</p>	<p>1</p>
	<p>&lt;Thick 4.0 mm&gt; Work clamp blank, UN-2 T=4.0</p>	<p>S21724-001</p>	<p>1</p>

**Blank for work clamp**

[Models BAS-342F]

	Part name	Part code	Qty
	<p>&lt;Thick 4.0 mm&gt; Work clamp blank, L T = 4.0</p>	S31244-001	1
	<p>&lt;Thick 4.0 mm&gt; Work clamp blank, R T = 4.0</p>	S31245-001	1

**For one-touch work clamp assy : Sewing area " 250 x 150 mm "**

[Models BAS-341F]

	Thick	Ref. No.	Part name	Part code	Qty	
	4.0 mm	203-1	OT – work clamp assy, 4	S47168-001	1	
		203-1-1	OT – work clamp, 4	S17983-000	1	
		203-1-2	Pin, one-touch	S47169-001	2	
		203-1-3	Screw, flat SM3.57 x 6	S01696-001	2	
	3.0 mm	203-1	OT – work clamp assy, 3	S47170-001	1	
		203-1-1	OT – work clamp, 3	S19593-000	1	
		203-1-2	Pin, one-touch	S47169-001	2	
	2.0 mm	203-1-3	Screw, flat SM3.57 x 6	S01696-001	2	
		203-1	OT – work clamp assy, 2	S47171-001	1	
		203-1-1	OT – work clamp, 2	S19595-000	1	
			203-1-2	Pin, one-touch	S47169-001	2
			203-1-3	Screw, flat SM3.57 x 6	S01696-001	2

**For one-touch work clamp assy : Sewing area “ 180 x 100 mm “**

[Models BAS-341F]

		Thick	Ref. No.	Part name	Part code	Q'ty
	4.0 mm		203-2	OT – work clamp assy, S4	S47614-001	1
			203-2-1	OT – work clamp, S4	S19615-000	1
			203-2-2	Pin, one-touch	S47169-001	2
			203-2-3	Screw, flat SM3.57 x 6	S01696-001	2
	3.0 mm		203-2	OT – work clamp assy, S3	S47615-001	1
			203-2-1	OT – work clamp, S3	S19617-000	1
			203-2-2	Pin, one-touch	S47169-001	2
			203-2-3	Screw, flat SM3.57 x 6	S01696-001	2
	2.0 mm		203-2	OT – work clamp assy, S2	S47616-001	1
			203-2-1	OT – work clamp, S2	S19619-000	1
			203-2-2	Pin, one-touch	S47169-001	2
			203-2-3	Screw, flat SM3.57 x 6	S01696-001	2

**For one-touch work clamp assy : Sewing area “ 300 x 200 mm “**

[Models BAS-342F]

		Thick	Ref. No.	Part name	Part code	Q'ty
	4.0 mm		203	OT – work clamp assy, 4	S47302-001	1
			203-1	OT – work clamp, 4 – 300	S30995-000	1
			203-2	Pin, one-touch	S47169-001	2
			203-3	Screw, flat SM3.57 x 6	S01696-001	2
	3.0 mm		203	OT – work clamp assy, 3	S47303-001	1
			203-1	OT – work clamp, 3 – 300	S30997-000	1
			203-2	Pin, one-touch	S47169-001	2
			203-3	Screw, flat SM3.57 x 6	S01696-001	2
	2.0 mm		203	OT – work clamp assy, 2	S47304-001	1
			203-1	OT – work clamp, 2 – 300	S30999-000	1
			203-2	Pin, one-touch	S47169-001	2
			203-3	Screw, flat SM3.57 x 6	S01696-001	2

**For one-touch work clamp assy : Sewing area “ 150 x 100 mm “**

[Models BAS-341F]

		Thick	Part name	Part code	Q'ty
		0.5 mm	OT – cassette plate assy, A150	S09378-001	1
		1.0 mm	OT – cassette plate assy, B150	S09379-001	1
		2.0 mm	OT – cassette plate assy, C150	S09380-001	1

For one-touch work clamp assy : Sewing area " 180 x 100 mm "

[Models BAS-341F]

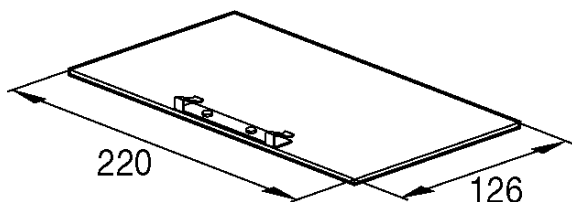
	Thick	Part name	Part code	Q'ty
	0.5 mm	OT – cassette plate assy, A180	S13695-001	1
	1.0 mm	OT – cassette plate assy, B180	S13697-001	1
	2.0 mm	OT – cassette plate assy, C180	S13698-001	1

Feed plate attachment

[Models BAS-341F]

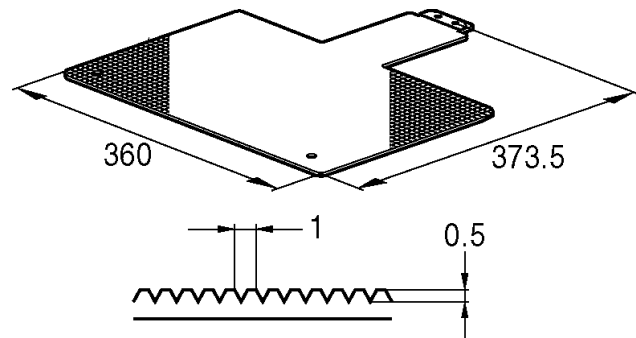
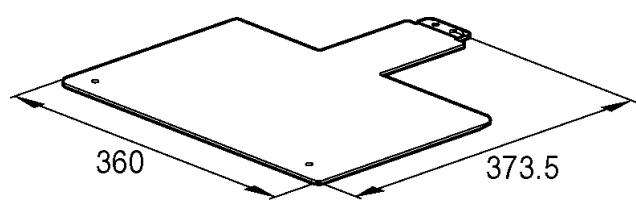
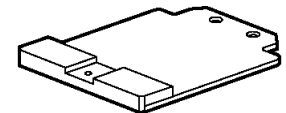
	Part name	Part code	Q'ty
	<p>&lt;Thick 1.0 mm&gt; Feed plate blank, A T = 1.0</p>	S47612-001	1
	<p>&lt;Thick 1.0 mm&gt; Feed plate blank, C</p>	S47613-001	1
	Feed plate setting bracket	S47624-001	1



**Feed plate attachment**

[Models BAS-342F]

	Part name	Part code	Q'ty
	<p>&lt;Thick 1.0 mm&gt; Feed plate blank, A - 300 T = 1.0</p>	S31256-001	1
	<p>&lt;Thick 1.0 mm&gt; Feed plate blank, C - 300</p>	S31257-001	1

**Work clamp attachment**

[Models BAS-341F]

	Part name	Part code	Q'ty
	Work clamp, SEU	S20756-001	1
	<p>&lt;Sewing area " 180 x 100 mm "&gt; Work clamp, SEU 180 x 100</p>	S19637-001	1
	<p>&lt;Sewing area " 150 x 100 mm "&gt; Work clamp, SEU 150 x 100</p>	S19638-001	1

**Work clamp attachment**

[Models BAS-341F]

	Ref. No.	Part name	Part code	Q'ty
	233	Work clamp, SEL - 326	S34156-001	1
	234	Work clamp, SER - 326	S34157-001	1

**Work clamp attachment**

[Models BAS-341F]

	Ref. No.	Part name	Part code	Q'ty
	235	OT – work clamp assy, SEL	S34158-001	1
	235-1	OT – work clamp, SEL	S34159-001	1
	235-2	Work clamp holder, L	S20282-001	1
	235-3	Bolt, socket SM4.37 x 8	018680-822	2
	235-4	Side plate	S20283-001	1
	235-5	Positioning pin	S20284-001	1
	235-6	Retaining ring, E3	048030-342	1
	235-7	Pin, spring roll 1.4 x 8	047140-850	1
	235-8	Spring	S20285-001	1
	235-9	Screw, pan M3 x 6	062300-612	2
	236	OT – work clamp assy, SER	S34160-001	1
	236-1	OT – work clamp, SER	S34161-001	1
	236-2	Work clamp holder, R	S20288-001	1
	236-3	Bolt, socket SM4.37 x 8	018680-822	2
	236-4	Side plate	S20283-001	1
	236-5	Positioning pin	S20284-001	1
	236-6	Retaining ring, E3	048030-342	1
	236-7	Pin, spring roll 1.4 x 8	047140-850	1
	236-8	Spring	S20285-001	1
	236-9	Screw, pan M3 x 6	062300-612	2

**Work clamp attachment**

[Models BAS-341F]

	Ref. No.	Part name	Part code	Qty
	237	(L) OT – work clamp assy, L	S34162-001	1
	237-1	(L) OT – work clamp, L	S34163-001	1
	237-2	(L) OT - Work clamp holder, L	S34166-001	1
	237-3	Bolt, socket M5 x 12	018501-222	2
	237-4	Side plate	S34169-001	1
	237-5	Positioning pin	S34168-001	1
	237-6	Retaining ring, E3	048030-342	1
	237-7	Pin, spring roll 1.4 x 8	047140-850	1
	237-8	Spring	S20285-001	1
	237-9	Screw, pan M3 x 6	062300-612	2
	238	(L) OT – work clamp assy, R	S34164-001	1
	238-1	(L) OT – work clamp, R	S34165-001	1
	238-2	(L) OT - Work clamp holder, R	S34167-001	1
	238-3	Bolt, socket M5 x 12	018501-222	2
	238-4	Side plate	S34169-001	1
	238-5	Positioning pin	S34168-001	1
	238-6	Retaining ring, E3	048030-342	1
	238-7	Pin, spring roll 1.4 x 8	047140-850	1
	238-8	Spring	S20285-001	1
	238-9	Screw, pan M3 x 6	062300-612	2

**Work clamp attachment**

[Models BAS-341F]

	Ref. No.	Part name	Part code	Qty
	239	(L) OT – holder assy, L	S34170-001	1
	239-1	(L) OT – holder, L	S34172-001	1
	239-2	Positioning stud	S34174-001	2
	239-3	Guide shaft	S34175-001	1
	239-4	Set screw, socket (FT) M6 x 6	S23651-001	1
	239-5	Adjusting plate	S33722-001	1
	239-6	Washer, plain S3.5	025350-134	2
	239-7	Screw, pan SM3.57 – 40 x 6	062670-616	1
	240	(L) OT – holder assy, R	S34171-001	1
	240-1	(L) OT – holder, R	S34173-001	1
	240-2	Positioning stud	S34174-001	1
	240-3	Guide shaft	S34175-001	1
	240-4	Set screw, socket (FT) M6 x 6	S23651-001	2
	240-5	Adjusting plate	S33722-001	1
	240-6	Washer, plain S3.5	025350-134	1
	240-7	Screw, pan SM3.57 – 40 x 6	062670-616	1

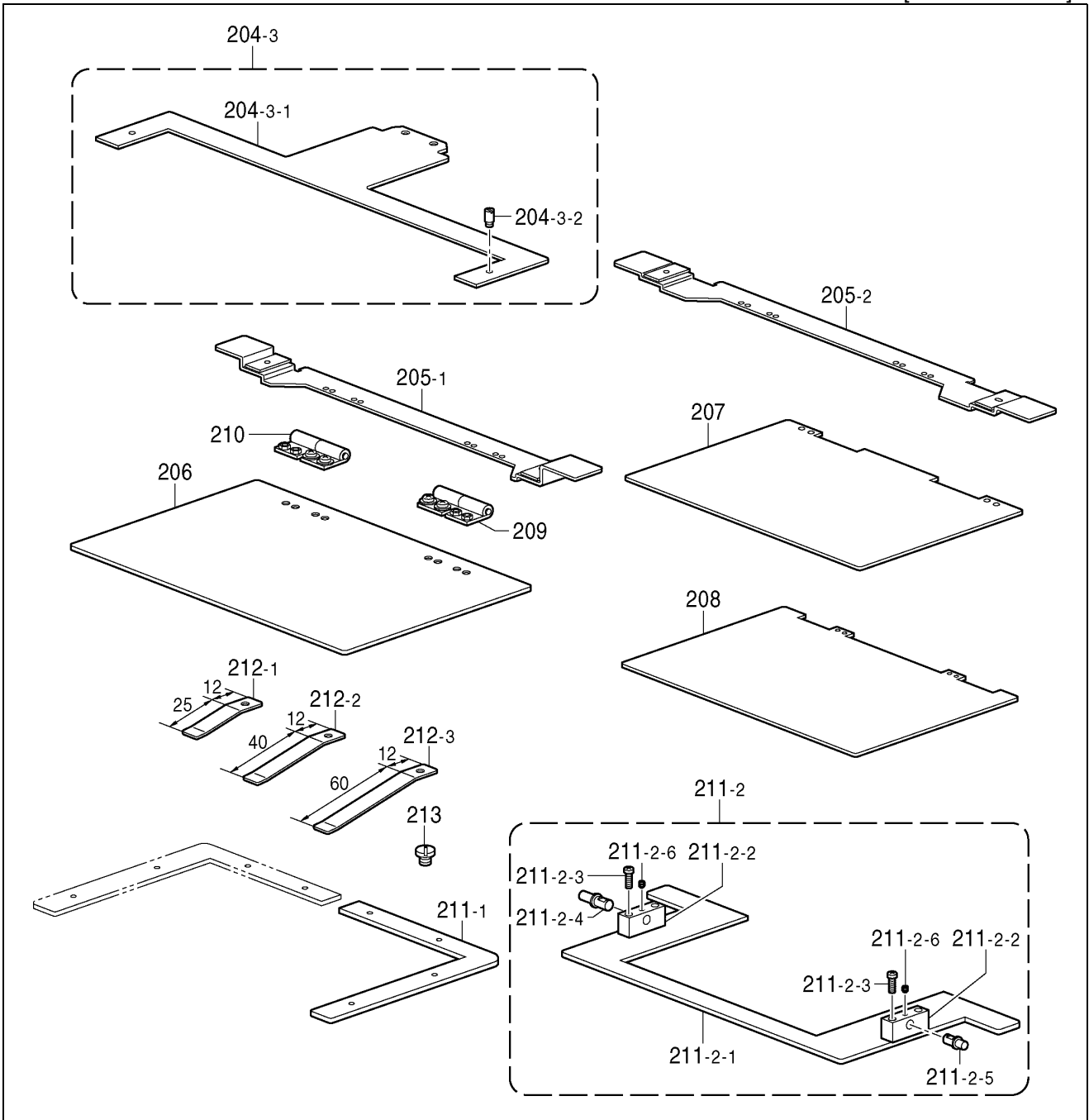

## Cassette feed attachment

[Models BAS-341F]

Ref. No.	Part name	Part code	Qty
204-3	C-holder plate assy, 341L	S47621-001	1
204-3-1	Holder plate, 341L cassette	S47622-001	1
204-3-2	Pin, cassette holder	S19629-001	2
205-1	Cassette plate	S19630-001	1
205-2	Cassette plate, 340L	S20755-001	1
206	Lower plate, cassette	S19631-000	1
207	Inner plate, 2T = 2.0 cassette····· t = 2.0	S19632-000	1
208	Upper plate, 1T = 1.0 cassette····· t = 1.0	S19644-000	1
208	Upper plate, 2T = 2.0 cassette····· t = 2.0	S19633-000	1
207	Inner plate, 1T = 1.0 cassette····· t = 1.0	S19643-000	1
209	Hinge assy, R	152632-001	1
210	Hinge assy, L	152633-001	1
211-1	Work clamp plate, C-1	S19634-001	1
212-1	Spring, plate 1 C - 1····· t = 0.4	S02853-001	1
212-2	Spring, plate 2 C - 1····· t = 0.6	S02854-001	1
212-3	Spring, plate 3 C - 1····· t = 0.8	S02855-001	1
213	Screw, SM4.37	107419-002	1
211-2	Work clamp plate assy, C - 2	S19914-001	1
211-2-1	Work clamp plate, C - 2	S19915-001	1
211-2-2	Hinge, work clamp plate	S17836-001	2
211-2-3	Screw, pan SM4.37 - 40 × 16	062681-612	4
211-2-4	Hinge shaft, LW - clamp plate	S17837-001	1
211-2-5	Hinge shaft, RW - clamp plate	S18014-001	1
211-2-6	Set screw, socket (CP) SM4.76	014710-522	2

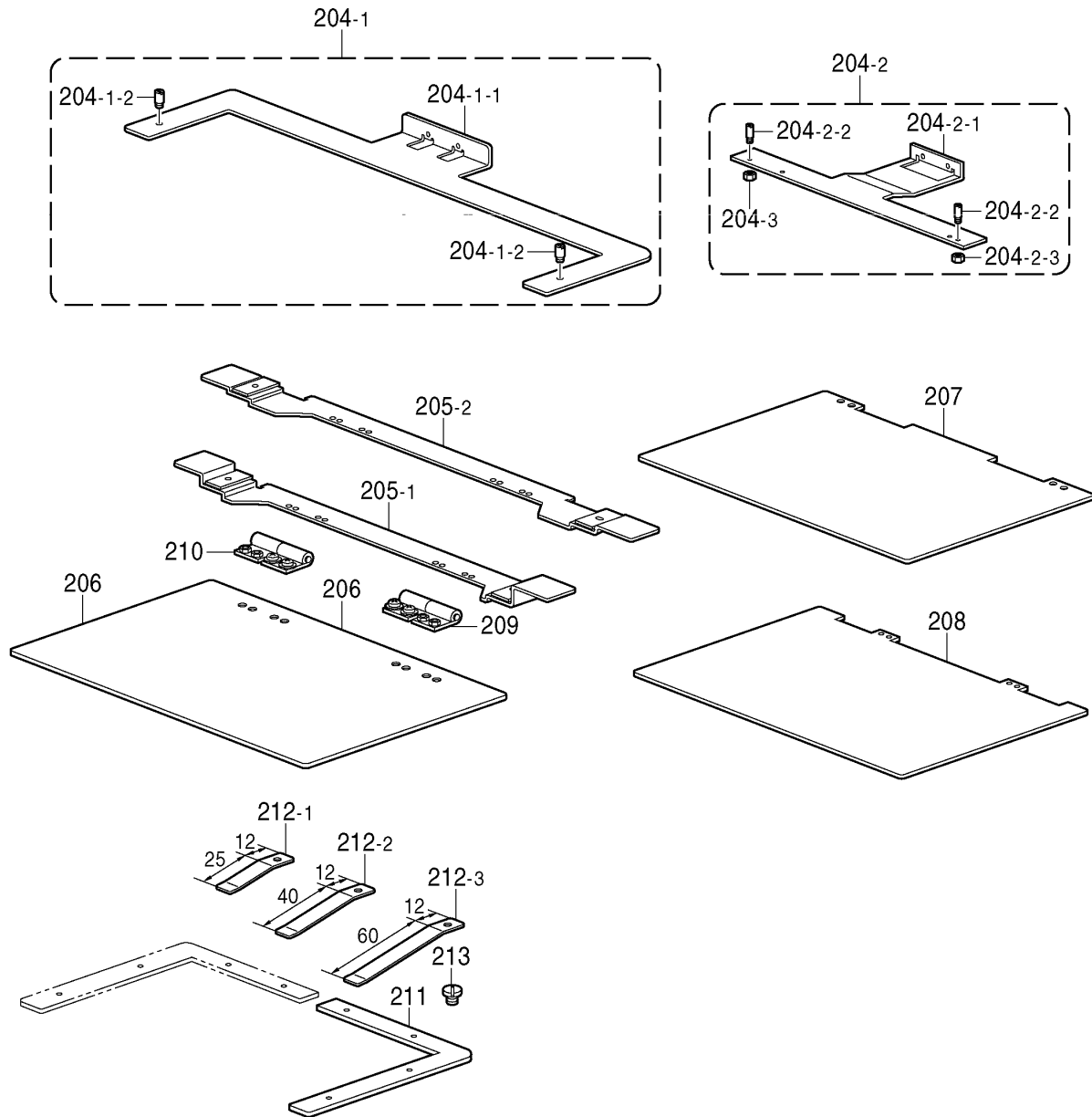

Ref. No.	Part name	Part code	Q'ty
204-1	C - holder plate assy, 342L	S31259-101	1
204-1-1	Holder plate, 342L cassette	S31260-101	1
204-1-2	Pin, cassette holder	S19629-001	2
204-2	c-holder plate assy, Z26	S33720-001	1
204-2-1	Holder plate, Z26 cassette	S33721-001	1
204-2-2	Pin, cassette holder	S13007-001	2
204-2-3	Nut, 3 SM3.18 - 40	021660-306	2
205-1	Cassette plate body	S19630-001	1
205-2	Cassette plate, 342L	S31261-001	1
206	Lower plate, cassette	S31262-000	1
207	Inner plate, 2T = 2.0 cassette ..... t = 2.0	S31263-000	1
207	Inner plate, 1T = 1.0 cassette ..... t = 1.0	S31264-000	1
208	Upper plate, 2T = 2.0 cassette ..... t = 2.0	S31265-000	1
208	Upper plate, 1T = 1.0 cassette ..... t = 1.0	S31266-000	1
209	Hinge assy, R	152632-001	1
210	Hinge assy, L	152633-001	1
211	Work clamp plate, C - 1 / 300	S31273-001	1
212-1	Spring, plate 1 C - 1 ..... t = 0.4	S02853-001	1
212-2	Spring, plate 2 C - 1 ..... t = 0.6	S02854-001	1
212-3	Spring, plate 3 C - 1 ..... t = 0.8	S02855-001	1
213	Screw, SM4.37	107419-002	1

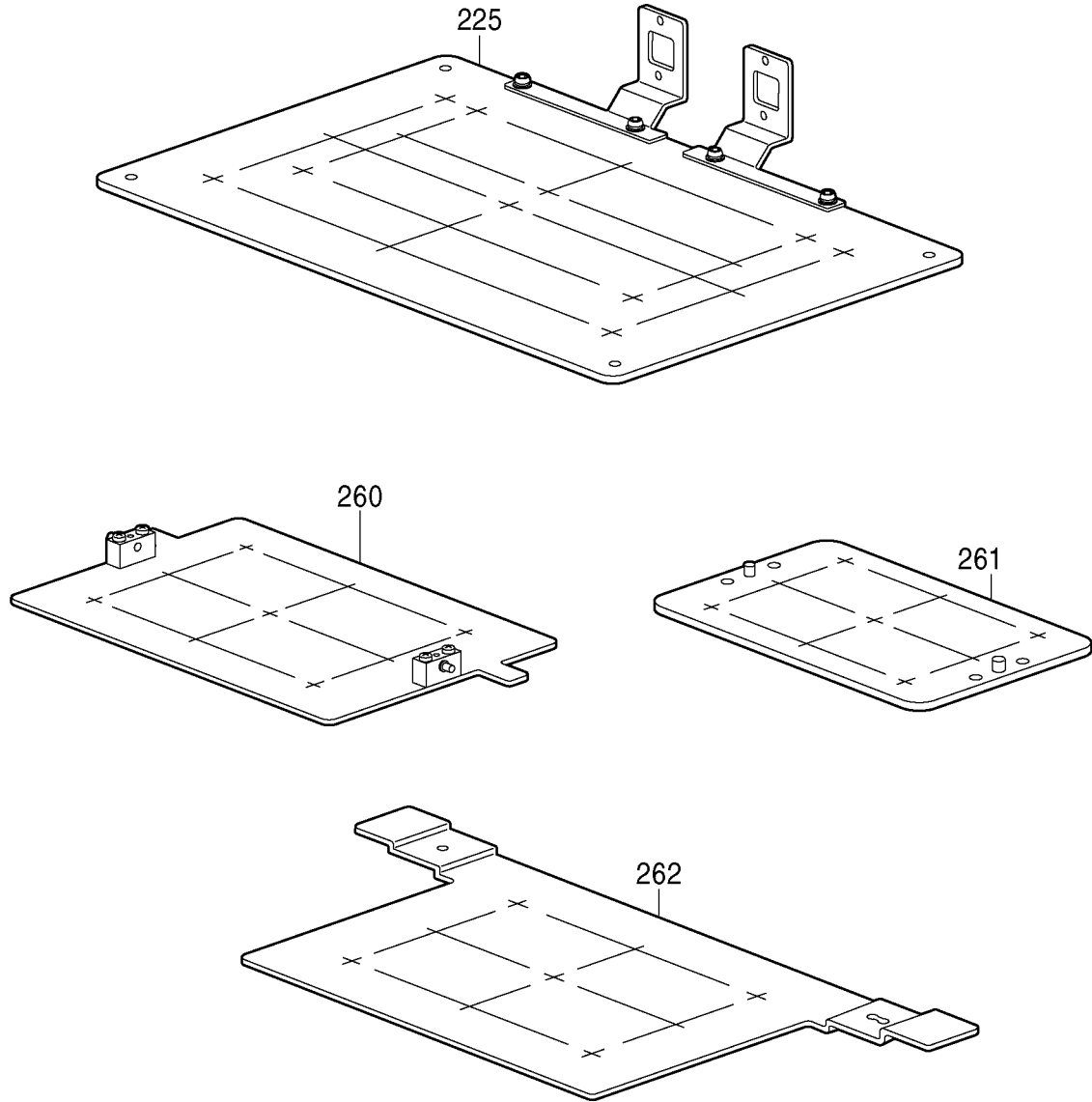

Ref. No.	Part name	Part code	Q'ty
225	H-position standard plate assy	S32035-001	1
260	Hinge support jig assy, 341	S47601-001	1
261	Jig assy, work clamp (UN) 341	S47603-001	1
262	Jig, cassette holder plate 341	S47606-001	1



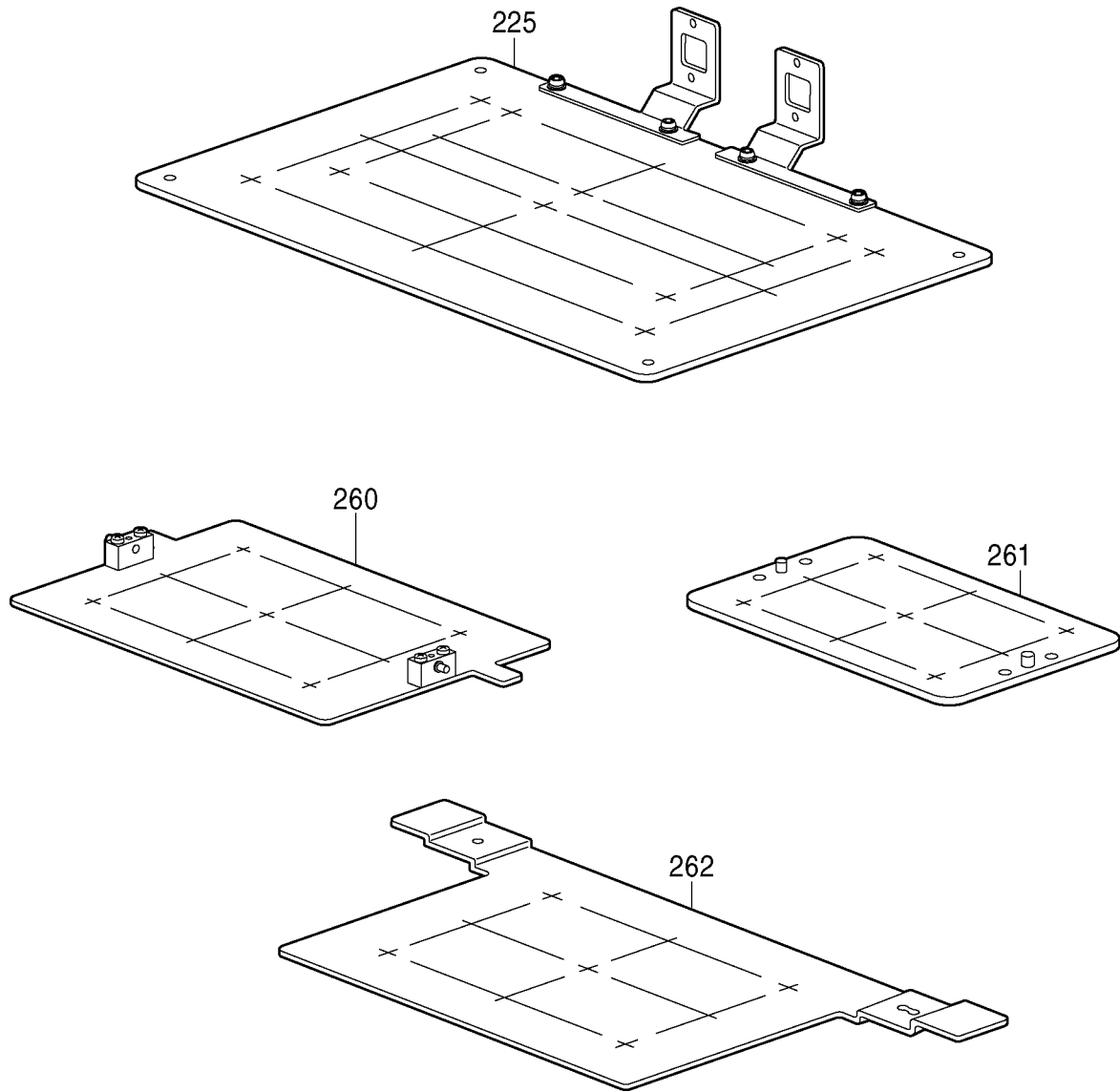

Ref. No.	Part name	Part code	Q'ty
225	H-position standard plate assy	S32035-001	1
260	Hinge support jig assy, 342	S47607-001	1
261	Jig assy, work clamp (UN) 342	S47609-001	1
262	Jig, cassette holder plate 342	S47611-001	1

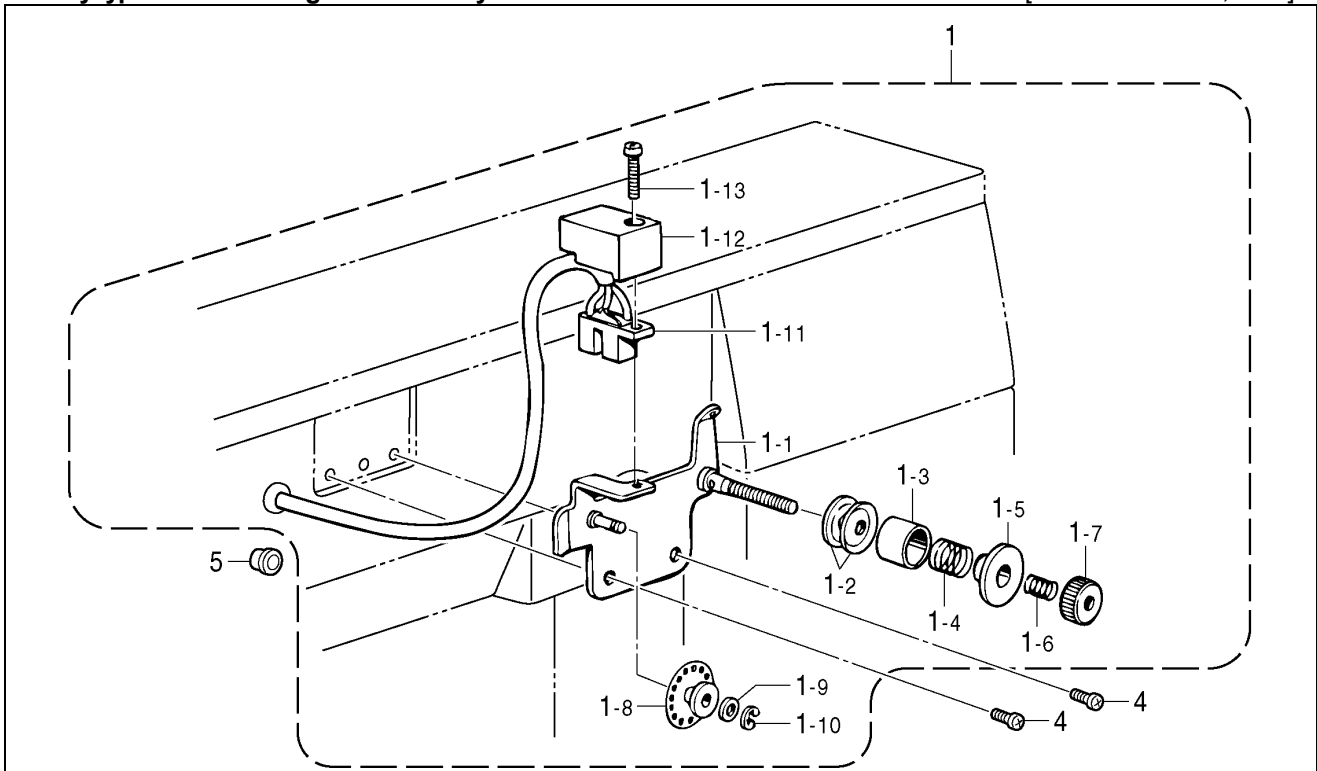

Ref. No.	Part name	Part code	Qty
1	TR. breakage detector assy, R	S43834-109	1
1-1	Detector bracket assy	S18032-001	1
1-2	Thread guide disc	144504-001	2
1-3	Thread guide disc presser	146206-009	1
1-4	Pre-tension spring	146058-001	1
1-5	Pre-tension nut	146059-001	1
1-6	Spring	146060-000	1
1-7	Tension nut	155510-001	1
1-8	Pulley, A	157255-100	1
1-9	Washer, plain S3	025030-135	1
1-10	Retaining ring, E2	048020-342	1
1-11	Sensor assy	S43835-100	1
1-12	Sensor cover	S18037-009	1
1-13	Screw, pan M3 × 16	062301-616	1
4	Screw, pan SM3.57 - 40 × 6	062670-612	2
5	Cord bush	146080-000	1

\*This thread breakage detector is standard.

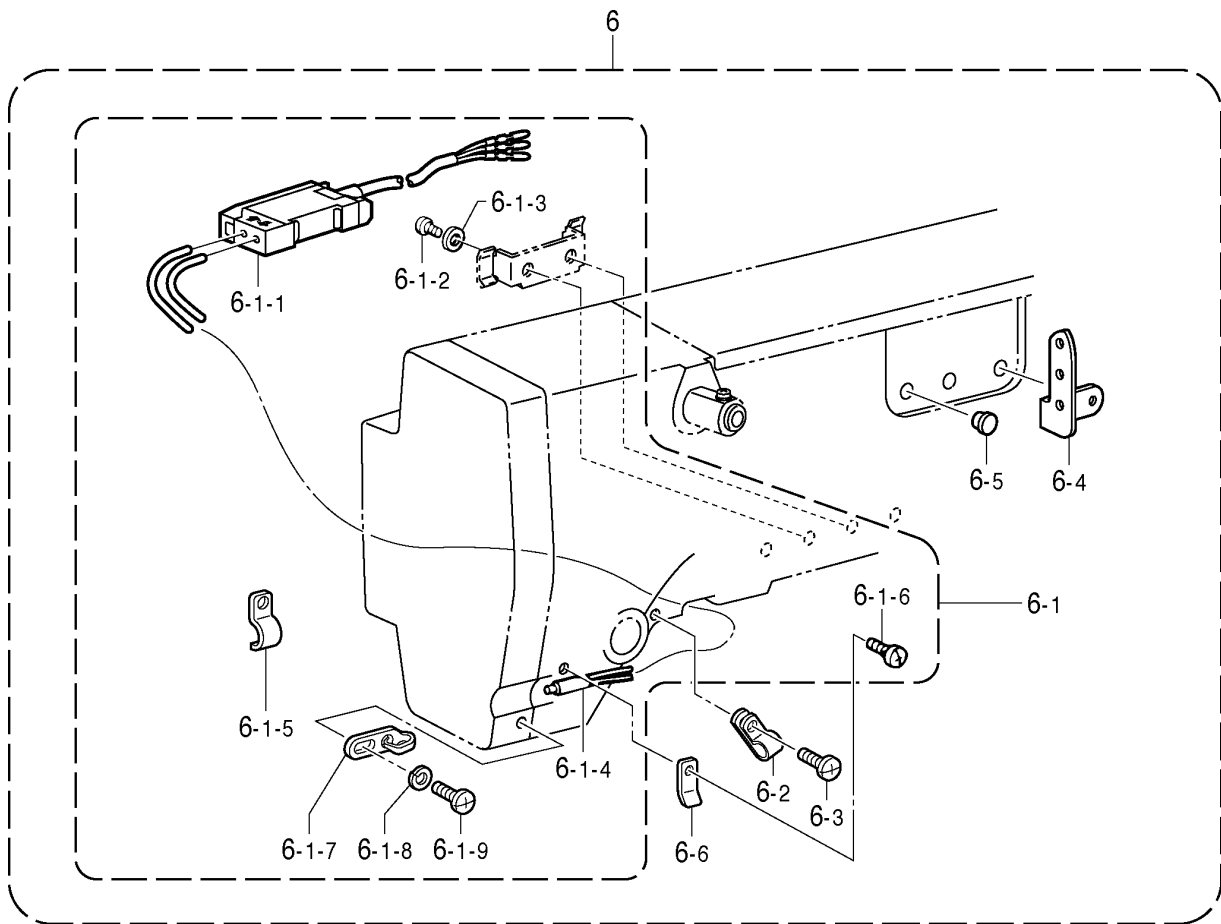

Ref. No.	Part name	Part code	Q'ty
6	TR. breakage detector set, F	S43836-301	1
6-1	TR. breakage detector assy, F	S43977-201	1
6-1-1	AMP unit	S43279-200	1
6-1-2	Screw, pan M3 x 6	062300-612	2
6-1-3	Washer, plain M3	025030-232	2
6-1-4	Fiber unit, N	S29468-100	1
6-1-5	Sensor setting plate	S11884-001	1
6-1-6	Screw, pan M3 x 6	062300-612	1
6-1-7	Face plate thread guide	S02617-001	1
6-1-8	Washer, spring 2-3.5	028350-242	1
6-1-9	Screw, bind SM3.57-40x6	060670-612	1
6-2	Nylon clamp NK-2N	625010-000	1
6-3	Screw, bind SM3.57-40x6	060670-612	1
6-4	Thread retainer	152889-001	1
6-5	Rubber cap, 9.4	117936-009	1
6-6	Cord holder	S02657-101	1

\*This thread breakage detector is optional.

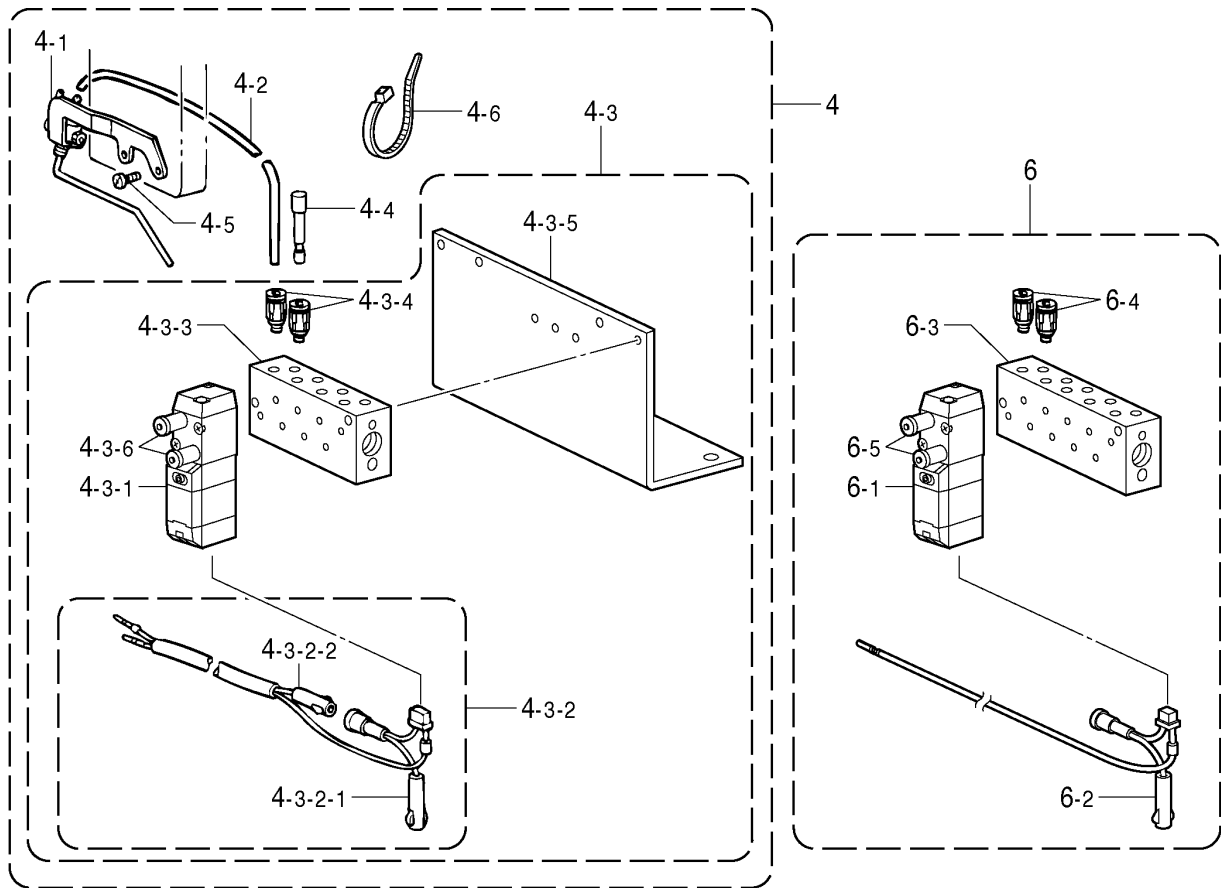

Ref. No.	Part name	Part code	Q'ty
	<Needle cooler set>		
4	Needle cooler set	S48503-109	1
4-1	Needle blower	S18027-101	1
4-2	Air tube, L=1900	S15031-008	1
4-3	Solenoid valve assy, OP4	S49437-008	1
4-3-1	Solenoid valve	S49432-001	1
4-3-2	Valve harness, x 1	S43696-000	1
4-3-2-1	Valve harness	S44746-000	1
4-3-2-2	Valve harness, 24V	S44750-000	1
4-3-3	Air manifold, 4	S18375-101	1
4-3-4	Half union, Q4M5	S18415-101	2
4-3-5	Setting plate, 4 – 5 valve	S31554-009	1
4-3-6	Exhaust throttle valve	S03792-001	2
4-4	Plug, 4	S04897-000	1
4-5	Screw, pan SM3.57-40 x 8	062670-812	2
4-6	Tying band 1.9x80	228475-000	3
	<Addition valve set>		
6	Solenoid valve assy, OP5	S54797-001	1
6-1	Solenoid valve	S49432-001	1
6-2	Valve harness	S44746-100	1
6-3	Air manifold, 5	S33956-000	1
6-4	Half union :Q4M5	S18415-101	2
6-5	Exhaust throttle valve	S032792-001	2

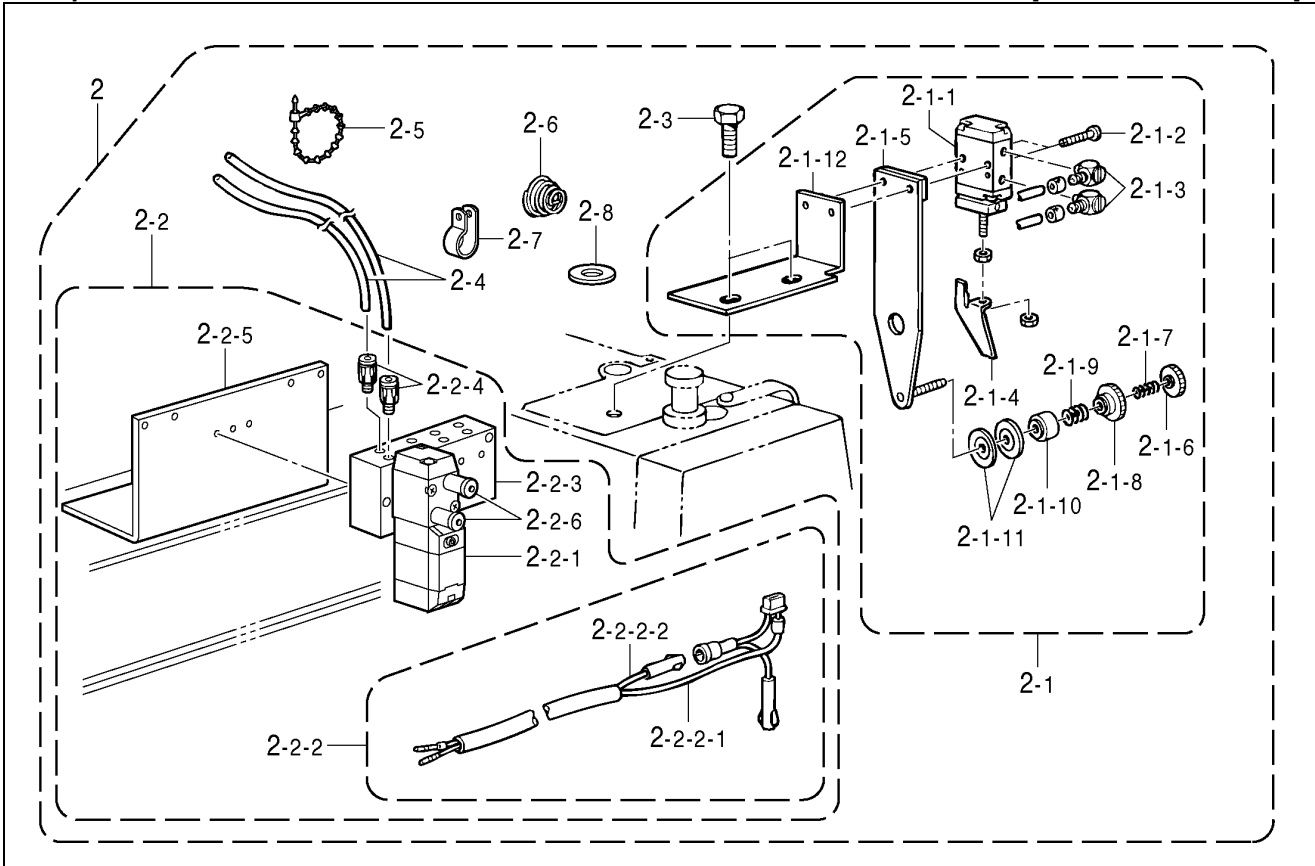

Ref. No.	Part name	Part code	Q'ty
2	2-step thread tension set, 2	S48501-101	1
2-1	2-step thread tension assy	S43838-001	1
2-1-1	Air cylinder, 10 x 10	S34706-000	1
2-1-2	Bolt, socket M3 x 20	018302-032	2
2-1-3	Tube elbow, M-5HL-4	S12150-000	2
2-1-4	Countersink claw	S34533-001	1
2-1-5	Sub tension bracket assy	S34534-001	1
2-1-6	Tension nut	155510-001	1
2-1-7	Spring	146060-000	1
2-1-8	Pre-tension nut	146059-001	1
2-1-9	Pre-tension spring	146058-001	1
2-1-10	Disk presser, thread guide	146206-009	1
2-1-11	Disc, thread guide	144504-001	2
2-1-12	Cylinder setting bracket	S34536-001	1
2-2	Solenoid valve assy, OP4	S49437-005	1
2-2-1	Solenoid valve	S49432-001	1
2-2-2	Valve harness, x 1	S43696-000	1
2-2-2-1	Valve harness	S44746-000	1
2-2-2-2	Valve harness, 24V	S44750-000	1
2-2-3	Air manifold, 4	S18375-101	1
2-2-4	Half union, Q4M5	S18415-101	2
2-2-5	Exhaust throttle valve	S03792-001	2
2-2-6	Setting plate, 4 - 5 valve	S31554-009	1
2-3	Bolt, SM7.94 x 18	017821-813	2
2-4	Air tube, 4L=1900	S15031-008	2
2-5	Bead band	340400-001	5
2-6	Spring, tension	104525-001	1
2-7	Cord holder, 7N	149287-000	3
2-8	Washer	S48180-002	1

From the library of: Diamond Needle Corp

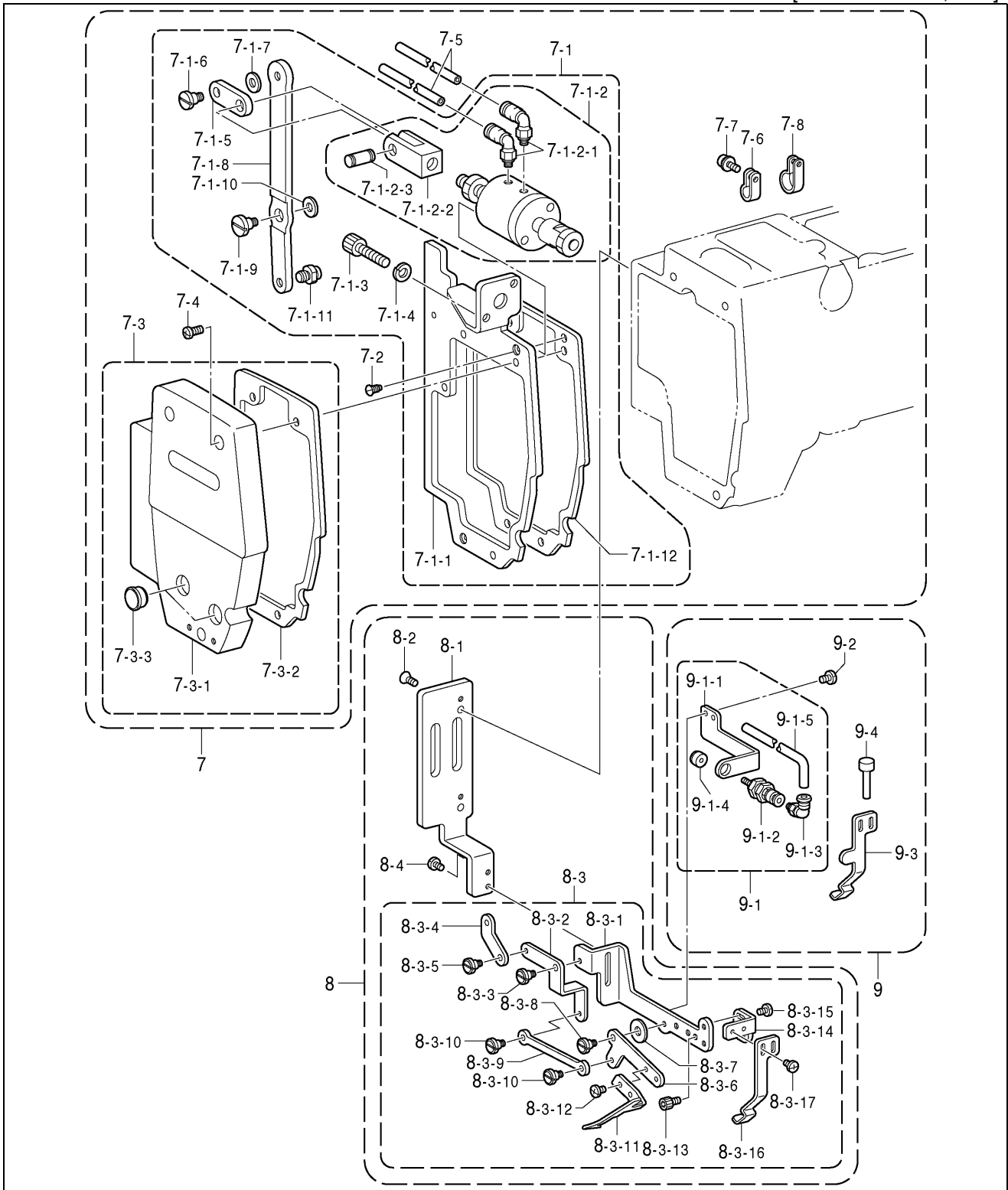

Ref. No.	Part name	Part code	Qty
	<Thread release cylinder set>		
9	Thread release cylinder set	S53155-001	1
9-1	Thread release cylinder assy	S53080-001	1
9-1-1	Cylinder bracket	S53081-001	1
9-1-2	Cylinder, 6x5	S16996-000	1
9-1-3	Elbow, M5	S18382-000	1
9-1-4	Needle thread presser	S16997-100	1
9-1-5	Air tube, 4x2.5 L=1900	S15031-008	1
9-2	Screw, bind SM4.37-40x5	060680-512	2
9-3	TR-presser, S	S53082-001	1
9-4	Plug, 4	S04897-000	1

**2-step work clamp device, Upper thread nipper & Thread release cylinder set**

[Models BAS-341F, 342F]

Ref. No.	Part name	Part code	Qty
	<2-step work clamp device>		
7	2-step work clamp device, 341	S54786-001	1
7-1	2-step work clamp assy, 341	S54787-001	1
7-1-1	Space, 341-F	S54788-001	1
7-1-2	Cylinder assy, 25-10	S51473-000	1
7-1-2-1	Elbow union, 4M5	S11426-000	2
7-1-2-2	Knuckle joint	S41523-000	1
7-1-2-3	Pin	S41524-000	1
7-1-3	Bolt, socket M6x20	018062-036	2
7-1-4	Washer, spring 2-6	028060-246	2
7-1-5	Link	S51476-001	1
7-1-6	Shoulder screw, SM6.35	150451-001	1
7-1-7	Washer, plain 6.5	153138-001	1
7-1-8	Lever	S51477-001	1
7-1-9	Shoulder screw, SM5.95	S19817-001	1
7-1-10	Washer, plain 6.5	153138-001	1
7-1-11	Roller shaft, w/screw SM6.35	S51478-001	1
7-1-12	Packing, F	S25155-100	1
7-2	Screw, flat SM4.37-40x8	100032-004	2
7-3	Face plate assy, 2SF ;341	S54790-009	1
7-3-1	Face plate, 2SF ;341	S54791-009	1
7-3-2	Packing, face plate ;2SF	S54792-000	1
7-3-3	Rubber cap, 13.5	117934-001	2
7-4	Screw, pan SM4.76-32x14	062711-412	3
7-5	Air tube, 4x2.5 L=2100	S15031-010	2
7-6	Cord holder, 6N	525664-000	1
7-7	Screw, pan (S/P washer) M4x8	0A5400-806	1
7-8	Cord holder, 8N	525567-000	4
	<U-thread nipper >		
8	U-thread nipper device	S53154-001	1
8-1	Solenoid base plate	S53071-001	1
8-2	Screw, flat SM4.37-40x8	100032-004	2
8-3	Thread nipper assy, 300E	S53070-001	1
8-3-1	Fulcrum plate, TR-nipper	S53072-001	1
8-3-2	Crank, TR-nipper	S53073-001	1
8-3-3	Shoulder screw, M4	S46842-001	1
8-3-4	Solenoid connecting rod	S53074-001	1
8-3-5	Shoulder screw, SM4.37	113730-001	1
8-3-6	Thread nipper bracket	S53075-001	1
8-3-7	Washer	S19543-001	1
8-3-8	Shoulder screw, M4	S46842-001	1
8-3-9	Thread nipper connecting plate	S53076-001	1
8-3-10	Shoulder screw, SM4.37	113730-001	2
8-3-11	Thread nipper	S53077-001	1
8-3-12	Screw, bind SM3.57-40x5	060670-512	2
8-3-13	Bolt, socket SM4.37x5	018680-522	1
8-3-14	Thread presser bracket	S53078-001	1
8-3-15	Screw, bind SM3.57-40x5	060670-512	2
8-3-16	Thread presser	S53079-001	1
8-3-17	Screw, bind SM3.57-40x5	060670-512	2
8-4	Screw, bind SM3.57-40x5	060680-512	2

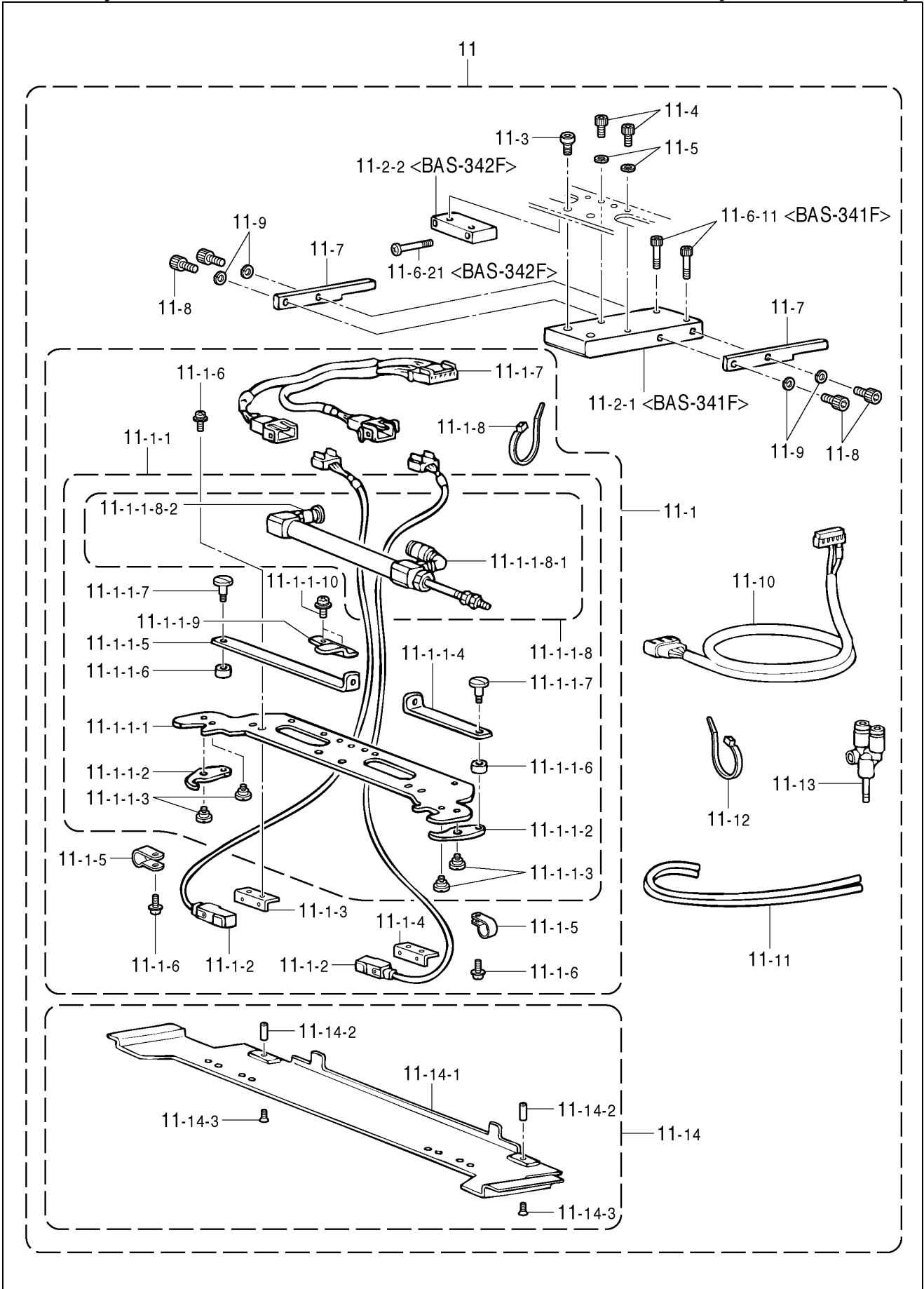



## Automatic ejector set

[Models BAS-341F, 342F]

Ref. No.	Part name	Part code	Qty
	<Automatic ejector>		
11	Automatic ejector set	S51429-101	1
11-1	Automatic ejector assy, H. S	S37761-101	1
11-1-1	Automatic ejector body assy	S37762-101	1
11-1-1-1	Automatic ejector body, 1C	S37763-101	1
11-1-1-2	Hook, AE	S37764-001	2
11-1-1-3	Shoulder screw, SM4.37	159269-001	4
11-1-1-4	Hook driving lever, 70	S37765-001	1
11-1-1-5	Hook driving lever, 180	S37766-001	1
11-1-1-6	Roller, w-clamp lifter	S02301-001	2
11-1-1-7	Shoulder screw, SM4.76	141499-001	2
11-1-1-8	Cylinder assy, 10-45	S37767-000	1
11-1-1-8-1	Elbow union, 4M5	S11426-000	1
11-1-1-8-2	Half union	S04905-000	1
11-1-1-9	Holder plate	S37768-001	1
11-1-1-10	Screw, pan (S/P washer) M4x8	052400-806	2
11-1-2	Hole sensor	S20083-000	2
11-1-3	Sensor bracket, L	S37769-001	1
11-1-4	Sensor bracket, R	S37770-001	1
11-1-5	Nylon clamp NK-2N	625010-000	2
11-1-6	Screw, pan (s/p washer) M3x8	533527-001	6
11-1-7	AE-sensor harness, A	S37780-000	1
11-1-8	Band, PLT1M	S04557-000	7
	<For BAS-341F>		
11-2-1	AE-setting plate, 341A	S37775-001	1
	<For BAS-342F>		
11-2-2	AE-setting plate, 342A	S37771-001	1
11-3	Screw, round w/socket SM4.37	S10352-101	2
11-4	Bolt, socket M4x10	018401-022	2
11-5	Washer, spring 2-4	028040-242	2
	<For BAS-341F>		
11-6-1	Bolt, socket SM4.37x18	150382-001	2
	<For BAS-341F>		
11-6-2	Screw, pan SM4.37-40x25	S31808-001	2
11-7	Guide plate	S37776-101	2
11-8	Bolt, socket M5x12	018501-222	4
11-9	Washer, spring 2-5	028050-242	4
11-10	Sensor harness, AE	S51426-000	1
11-11	Air tube, 4x2.5 L=1900	S15031-008	2
11-12	Band, PLT1M	S04557-000	5
11-13	Branch, UY-4	S08178-000	2
11-14	AE-cassette plate assy, 342	S37772-101	2
11-14-1	AE cassette plate, 342	S37773-001	2
11-14-2	Pin	S37774-001	4
11-14-3	Screw, flat M4	S25310-101	4